

SFL Cizo, Electrical socket Schuko (2x), USB A 2A (2x), Kabel 2 m, Mattschwarz



Parameter

Farbe	Schwarz
Marke	SFL
Socketyp	Französisch Type E
230 V Ausgänge	2
Andere Ausgänge	USB A
Katalog Seite	13.65
Hersteller Produktbezeichnung	SC035N
Menge im Karton	10

Produktbeschreibung

Steckdose mit Ladegerät USB A (2x). Netzkabel 2 m mit Stecker.

Weitere Bilder



Ähnliche Artikel

SFL Cizo, Electrical socket Schuko (2x), USB A 2A (2x), Kabel 2 m, matt white
F003418



Anleitung

IROSAN



Installation instructions - Please keep safe
Conserver les instructions de montage s'il vous plait
Montageanleitung - Bitte aufbewahren
Si prega di conservare le istruzioni di montaggio
Por favor conserve las instrucciones para el montaje



CIZO_manual_220203



To safely make an electrical connection (article 2 D.B.T.) : **Be sure to turn off the power of the housing.**

Pour effectuer un raccordement électrique en toute sécurité : **Veillez à couper l'alimentation générale de l'habitation.**

Alle Montagearbeiten im spannungslosen Zustand durchführen **Es sind die jeweiligen gültigen VDE Richtlinien zu beachten.**

Per effettuare la connessione elettrica dell'apparecchio in modo sicuro, **assicurarsi di spegnere l'alimentazione principale.**

Para hacer una conexión eléctrica segura, **asegurese de apagar la alimentación principal.**

16 A - 230 V - (USB 5V - 2,1A max)

3680 W MAX

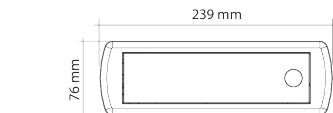

FB	CIZO-1
SCHUKO	CIZO-2
SW	CIZO-3

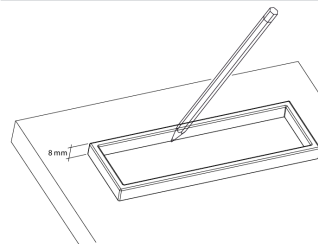
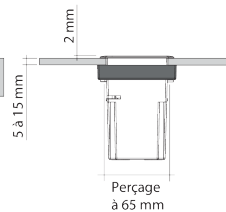
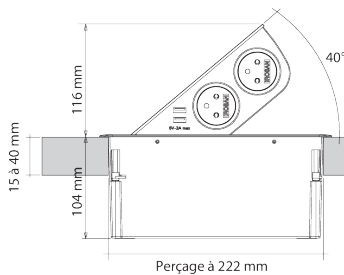
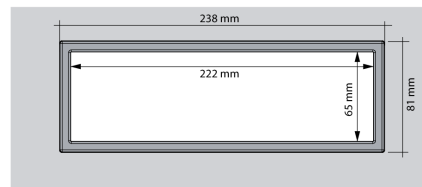

Réglementation DEEE (déchets des équipements électriques et électroniques)
 Un produit marqué du logo poubelle barrée doit être déposé dans un point de collecte.
 Il ne doit pas être jeté avec les ordures ménagères.
 Vous contribuez ainsi à préserver les ressources naturelles et à protéger la santé humaine.

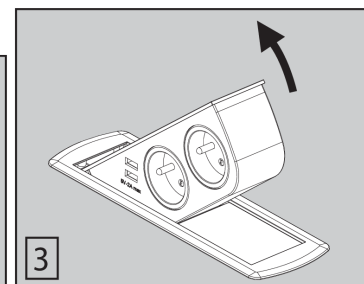
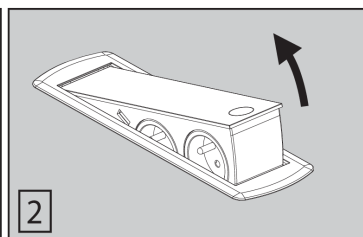
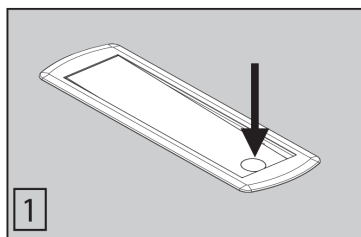
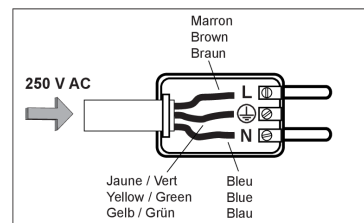
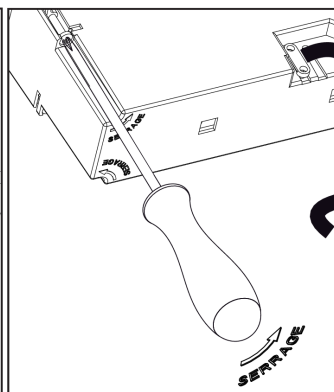
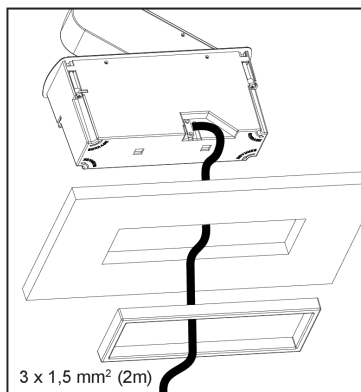

2D-Zeichnung

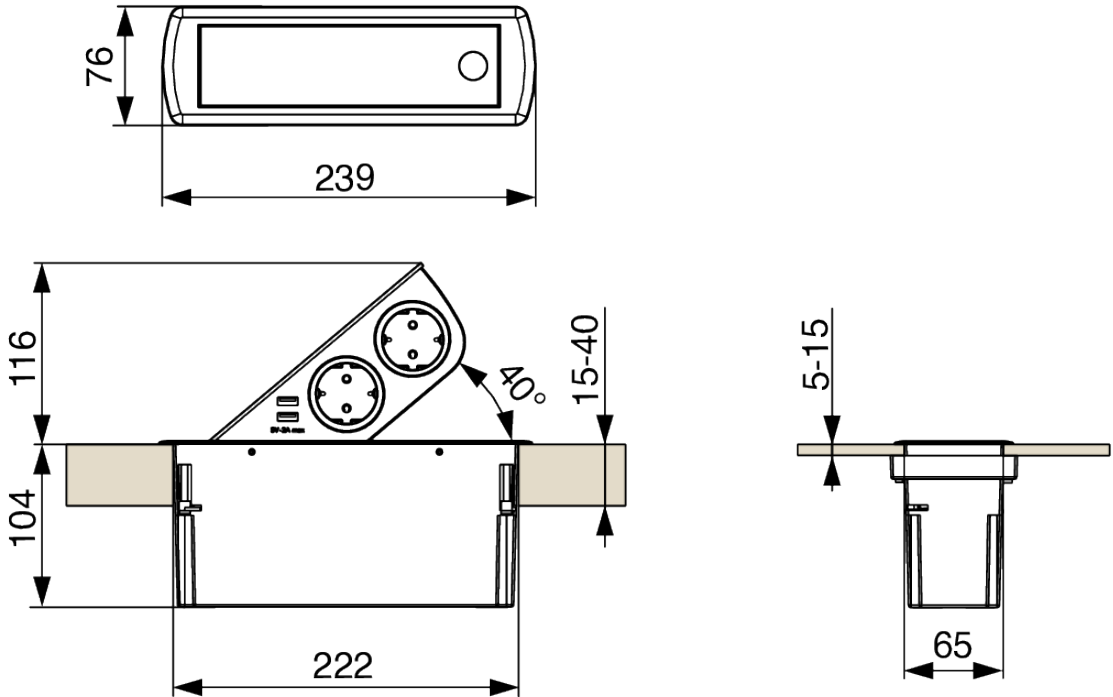

Konformitätserklärung

UE DECLARATION OF CONFORMITY



SFL (Société de Fabrication de Luminaires)
Technoparc EPSILON
65 rue Isaac Newton
83700 Saint Raphaël

declare that **SC035N** (ref : CIZO-2) built-in 2 sockets class I IP20 230V 50Hz 16A, 3600W max and 2 USB socket 5V – 2A max

comply with the provisions of the European Communities Council Directives including the latest amendments and last harmonized standards:

- 1) **Electrical safety :**
Directive 2014/35/UE of February 26th 2014
IEC 60884-1 : 2002 + A1 : 2006 + A2 : 2013
DIN VDE 0620-1 : 2016
- 2) **Electromagnetic compatibility :**
Directive 2014/30/UE of February 26th 2014
EN 61000-3-2 : 2014
EN 61000-3-3 : 2013
- 3) **RoHS :**
Directive 2011/65/UE of October 4th 2011
EN 62321 : 2009
EN 50581 : 2013
- 4) **Electrical and Electronic Equipment wastes :**
Directive 2012/19/UE of July 4th 2012
- 5) **Eco conception :**
Directive 2009/125/UE of October 21st 2009
- 6) **Environmental display:**
Directive 2010/30/UE of June 18th 2010
Regulation 874/2012

Made at Saint Raphaël on: 2023.04.19

Stéphane VERON
CEO

P.O.

DE031 - 13/12/2012 - R : 3

WEEE Policy Document



WEEE Registration

Hranipex Ltd complies with WEEE (Waste electricals and electronic equipment) regulations 2006.

We are registered directly under this scheme (Registration number: WEE/AX4945YF).

All Items subject to these regulations are appropriately marked.

We are constantly reviewing our WEEE obligations to ensure we comply with regulations.

Hranipex Ltd
Unit 2, Radial Park
Solihull Parkway
Birmingham Business Park
Birmingham, B37 7YN
United Kingdom

T +44 121 767 91 80
E uk-hranipex@hranipex.com
W www.hranipex.co.uk
CN: 07754143, VAT: 120037966
EORI: GB120037966000/

Citi Bank, Sort code: 18-50-08
Swift/BIC: CITIGB2L
GBP Acc. no.: 17882769
IBAN: GB58CIT118500817882769

Citi Bank, Bank code: 2600
Swift/BIC: CITICZPX
EUR Acc. no.: 2530440301
IBAN: CZ562600000002530440301